

WARRANTY

WARRANTY CONDITIONS

Warranty Period shall start on the date of invoice of the product and is 2 years.

1- All of the products, including all of its parts, are under the warranty of our company.

2- In case that the product becomes defective during warranty period, the period to elapse in repair shall be added to the warranty period. Delivery period for the product shall be 30 business days. This period starts from the date of delivery of the product to the service station, or, in the lack of service station, to any of the seller, dealer, agency, representative, importer or exporter of the product. In case that the defect of the industry product could not be corrected in 15 days, the importer or exporter is required to allocate to the use by the consumer another product that has similar specifications until the repair of the product is completed.

3- In case that the product becomes defective due to material or production errors within the warranty period, it shall be repaired without claiming for any workmanship cost, cost of replaced part or any other charge under any name whatsoever.

4- In spite of the consumer using the right of repair, if the product

a) becomes defective for the same fault more than twice in the same year following the date of delivery to the consumer, or different defects occur more than four times, provided that these shall remain within the warranty period specified, or is the sum of difference defects within the specified warranty period is more than six times, and additionally these defects make inability to use the product continuous,

b) the maximum period required for repair is exceeded,

c) the company does not have a service station;

upon the agreement of the producer and if it is determined that it is not possible to repair the defect with a report to be prepared one of the seller, dealer, agency, representative, importer or exporter of the product in the same order, the consumer may as for free replacement of the product, return the price thereof, or ask for discount equal to the rate of defect.

5- All these warranty conditions are applicable if there are no issues which exclude the product from warranty scope.

ISSUES WHICH EXCLUDE THE PRODUCT FROM WARRANTY SCOPE

- Using the product in violation of and/ or without respect to the issues specified in the Assembly and Operating Manual,
- Using well water, or water which has a value exceeding the PH (min 6.5 - max 8), total hardness (max. 25 Fr), chloride (max 500 ppm) limits, which is deforming, corrosive, calcifying in the installation during the initial start-up or thereafter even for testing purposes, ,
- Using substances such as inhibitor, anti-freeze, pH regulator, anti-calcification and anti-bacterial, chemical claimed to increase radiator efficiency etc. without written approval of RADYAL.
- Not making the building and installation grounding in accordance with regulations,
- Making erroneous installation or faulty mounting not in compliance with the installation technique,
- Not using pressure reducer in installations where water input pressure is higher than 10 bars,
- Finding corrosive and clogging substances such as sand, construction debris, plaster etc. in the installation water,
- Defects that occur with the freezing of the installation water,
- Damages that occur due to falling and colliding during loading, transportation, unloading, stocking or mounting.
- Trying to clean the radiators with hard or corrosive cleaning substances, and defects that occur on the surface for that reason,
- The product being exposed to corrosive effect arising from storage conditions at the construction site prior to mounting, or being impacted etc.
- Failure to present the warranty document, or making any alteration on the warranty document, shall exclude the product from warranty scope.

For any disputes with regard to warranty period, the invoice date shall be taken as basis and it is necessary to present the invoice.

RADYAL ISITMA SİSTEMLERİ A.Ş.

Merkez: Libadiye Cumhuriyet Mah. Mehmet Akif Ersoy
Cad. No.42 Üsküdar/ İSTANBUL

T: +90 850 308 08 08 **W:** www.radyal.com **M:** info@radyal.com

DATE, STAMP AND SIGNATURE

--

TOWEL WARMER ASSEMBLY AND USER GUIDE

ISSUES TO PAY ATTENTION PRIOR TO ASSEMBLY

RADYAL ALUMINUM RADIATOR shall be assembled and commissioned by expert persons with experience in aluminum radiator in compliance with the principles specified in the assembly guide and standards related to installation principles in heating systems.

Prior to mounting the radiators to the installation, make relevant checks and cleaning or have these made, in order to make sure that there is no construction debris or chemical substance in the heating device as well as overall installation. Debris or chemicals that are present in the heating device or installation may clog the water canals of the radiator or may damage the water canals of the radiator. Damages to be caused by chemicals or debris shall be outside the warranty scope.

Pressure reducer shall be used in installations where water input pressure is higher than 10 bars. Problems that occur from not using pressure reducer shall be excluded from warranty scope.

The system shall be grounded against electricity leakage. The product shall be excluded from warranty scope of there is no grounding.

Check that hot water input - output connections to the radiator are correct. Ways of connection not in compliance with installation rules shall prevent the operation of your radiator.

Mount your radiator without removing from its nylon packaging. Remove the protective nylon before use after all modification and painting works are completed. (Initial commissioning operation could be performed while the protective nylon is on the device)

RADYAL radiators can be easily mounted to the wall with the help of consoles. Radiator valve connections are G 1/2". Radiator valves to be used shall be chromium or nicked coated. All elements required for assembly are inside the packaging.

ISSUES TO PAY ATTENTION DURING ASSEMBLY

Locate the radiators on the consoles by means of the hanger elements at the back.

Make sure that the radiators is at scale after being placed on the console. If there is any slope in the radiator, some slices may not heat up, preventing operation with full efficiency.

ISSUES TO PAY ATTENTION DURING AND AFTER COMMISSIONING

DO NEVER USE WELL WATER in your system (even if for testing the heat system).

Using well water, water with hardness over 25 Fr and pH value outside the 6,5 - 8 interval (with acidic or basic character) shall exclude the product from warranty.

After the assembly is completed, perform initial water filling to the installation and after a water circulation of 5 minutes, make sure that you evacuate all water and remove all construction and installation debris.

Fill the installation with water, heat the radiators, and evacuate the air of radiators using the air relief clock at the corner of the radiator. Repeat the air evacuation process in a few following heating. If the radiator sounds as if water is flowing inside, this means that air is trapped in. In this case repeat the air evacuation process.



Do not add any chemical substance (inhibitor, anti-freeze, pH regulator, anti-calcification and anti-bacterial agent, chemicals claimed to increase radiator efficiency etc.) which is not approved by RADYAL in writing. Otherwise the radiators will be excluded from warranty scope.

System (or combi boiler) filter shall be checked as certain intervals, and any clogging shall be cleaned. If the filter is clogged, the efficiency will decrease since there will not be sufficient amount of water circulation in the radiators.

Take relevant measures in order to prevent freezing of water in the installation. Freezing of the water will damage the radiator and damage caused by the freezing water will be excluded from warranty.

Do never clean your radiator with a hard cleaning materials that leave marks. Do not use any chemical such as bleach, hydrochloric acid etc., and clean with a wet and soft cloth. Chemicals and corrosive substances will damage the paint or eloxal layer on the radiator. Damages to occur in this way are excluded from warranty.

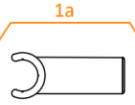
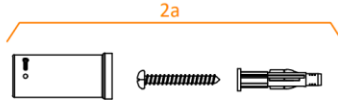
1) Adjustable mounting apparatus for each model (x3 pieces) consists of the parts in the image given below. (In the Zambak model, the mounting bracket is given as x4.)

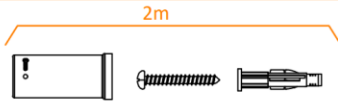
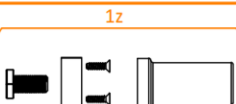
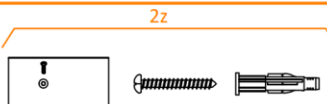
		a) Akasya, Violet, Violet Line, Violet Elite, Erguvan Light
		m) Manolya Elite, (Line)
		z) Zambak

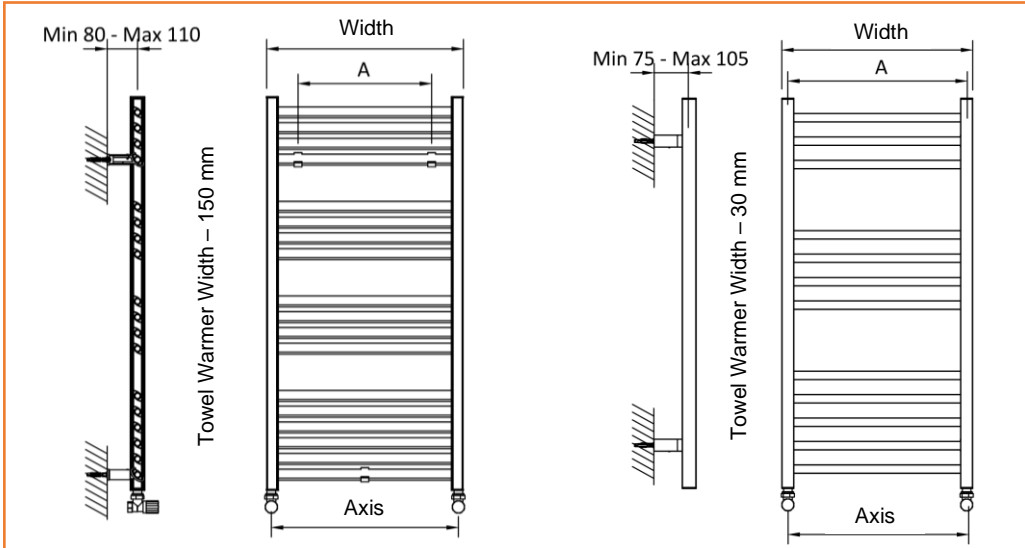

a) Akasya, Violet, Violet Line, Violet Elite, Erguvan Light
(Axis = Width - 25 mm)

m) Manolya Elite, Manolya Elite Line (Axis = Width - 25 mm)

z) Zambak: On the back of the product in the lily model
There are 8 holes. 1z assembly parts
Fix the mounting parts in the holes using
(Axis = Width - 30 mm)

Note: In Manolya Elite standard models, attach the hanger apparatus to the 2nd slices from the bottom and top. (When the distance between the pipes is 30 mm or less, attach the hanger apparatus to the top and bottom pipe.)

2) While fixing the 2a, 2m 2z groups to the wall, leave the valve distance margin of 40 mm and fix it at A / 2 distance by determining the b distance according to the pipe to which we want to attach the lower hanger apparatus. In the same way, fix the upper apparatus by determining the distance c according to the pipe you want to attach.

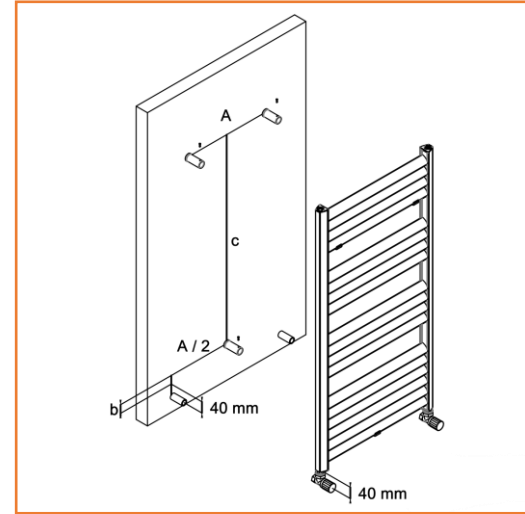

3) Fix the 1a, 1m, 1z groups to the towel warmer as shown below in the mounting apparatus of all models whose figures are given.

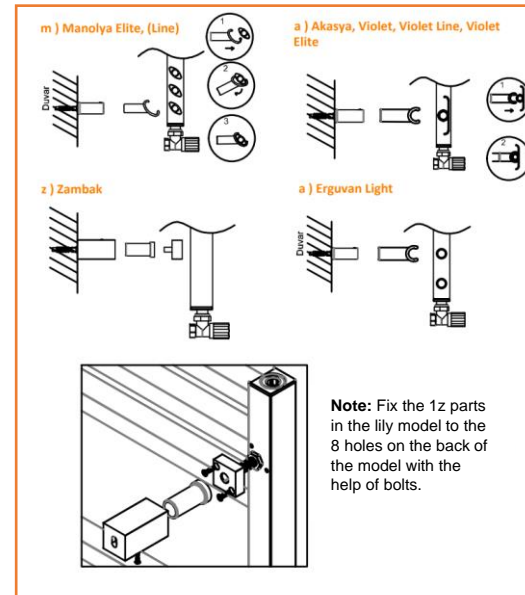

4) Fix the assembly parts with the fixing bolt by interlocking them.

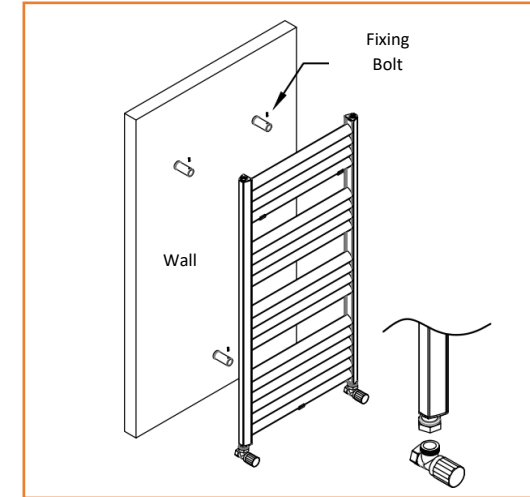

5) Make valve connections.

TOWEL VALVE CONNECTION TYPES

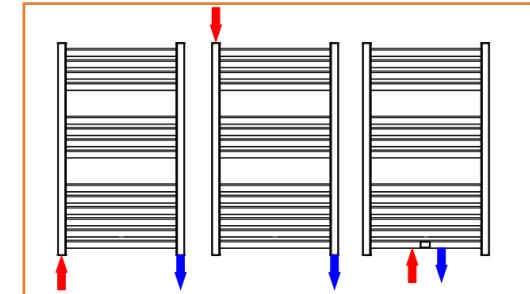

ELECTRIC TOWEL WARMER

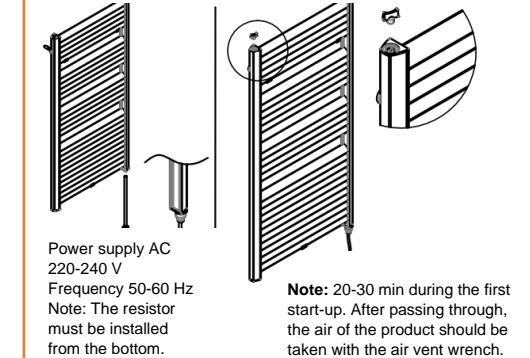

Note: 20-30 min during the first start-up. After passing through, the air of the product should be taken with the air vent wrench.