



Model: Lily

 **radyal**
aluminiumradiator

-Keep your life warm-







Please Read This Manual First!

Our dear customer,

Thank you for choosing the Radyal Electric product. We want our product, which is produced with high quality and technology, to offer you the best efficiency. For this purpose, before using the product, carefully read the entire manual and other documents provided and keep them for future reference. If you give the product to someone else, also provide the user manual with it. Heed all warnings and information contained in the user manual.

Meanings of symbols

The following symbols are used in various sections of this user manual:

	Important information or beneficial tips related to use		Fire danger alert
	Warning against conditions hazardous for life and property		Warning against hot surfaces.
	Warning for action which shall never be done.		Warning against electric shock.

Contents;

1. Important safety precautions
2. Display of parts
3. Assembly instructions
4. Operation
5. Other
 - 5.1 Safety features
 - 5.2 Cleaning and maintenance instructions
 - 5.3 Main technological features
6. Consumer services

1. Important safety precautions

When using electrical appliances, to reduce the risk of fire, electric shock and injury, one should always follow the basic precautions, which include:

- Read all instructions before using the product.
- This product is hot during use. To avoid burns, do not let your bare skin come into contact with hot surfaces.
- Extreme care should be taken when the product is used near children and leaving it unattended.
- Unplug the product from the power outlet when not in use.
- If special precautions need to be taken during the installation of the device, appropriate details should be given.
- If the supply cord is damaged, it must be replaced by Radyal Technical Service or services authorized by Radyal in order to avoid a dangerous situation.
- Do not use the product outdoors. This product is designed for indoor use only.
- Do not route the power cord under the carpet and do not cover the cord with rugs, runners, etc. Route the power cord through places where people do not pass or trip over.
- To disconnect, turn all controls to the 'off' position, then unplug the power plug from the outlet
- Do not use the product in greenhouses and construction sites.
- Use the product only as specified in this manual. Using the device other than the manufacturer's instructions may result in fire, electric shock, or personal injury.
- The radiator should not be placed directly below an electrical outlet.
- In order to avoid any hazard, if the power cord is damaged, it must be replaced by the manufacturer, the manufacturer's service centre or a similarly licensed person.
- The instructions for fixed devices should specify how to fix the device to its support. Since the stated fixation method cannot be considered a reliable fixation method, it is not dependent on the use of adhesive.
- Installation instructions for fixed towel rails should include the following.
- **WARNING:** To avoid danger to very young children, this appliance must be installed with the lowest heated rail at a height of at least 600 mm above the floor.
- This appliance can be used by children aged 8 years and above and persons with reduced physical, sensory or mental capabilities or lack of experience and knowledge if they have been given supervision or instructions about its safe use and understand the hazards involved. Children should not play with the device. Cleaning and user care should not be carried out by unattended children.
- **Proper disposal of this product**
This marking indicates that this product should not be disposed of with other household waste in EU countries. To prevent potential harm to the environment or human health from uncontrolled waste disposal, recycle the product responsibly to support the sustainable reuse of material resources. To recycle your used device, please use the recycling or collection systems or consult the retailer where you purchased the product. They can take the product from you for environmentally safe recycling.



- This product is a dry type heater, it does not contain any liquid.

- Children under the age of 3 should be kept away from the product unless they are under constant supervision. Children aged 3 to 8 years may only switch the appliance on or off when it's placed or installed in its normal operating position if they have been given supervision or instruction concerning use of the appliance in a safe way and understand the hazards involved. Children between the ages 3 and 8 should not plug the device into the socket, and should not make adjustments, cleaning or user maintenance on the device.



Warning: some parts of this product may overheat and cause burns. It is necessary to pay special attention to environments where there are children or people who need to be supervised.

2. Display of parts

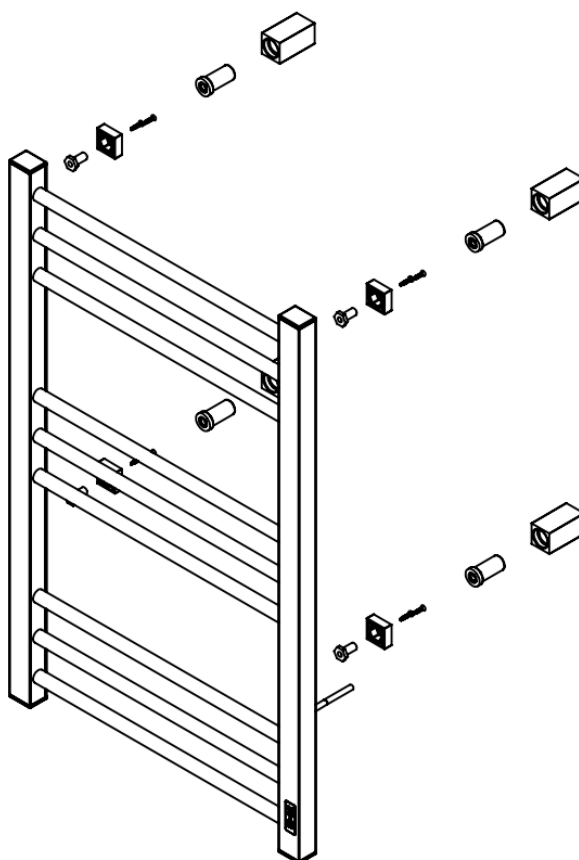

3. Assembly instructions

- 1- Fasten the small square pieces to the product.
- 2- Fasten the round parts to the bolt.

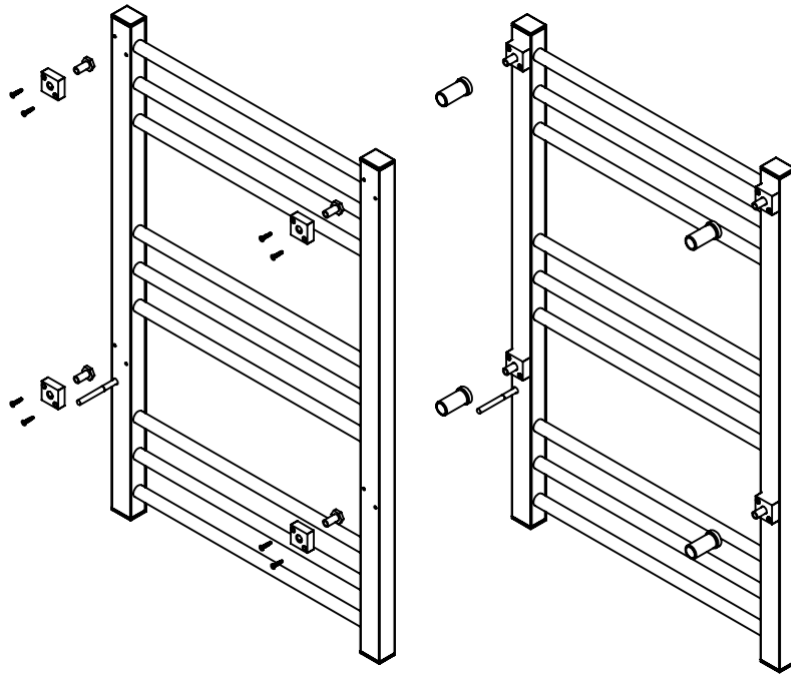

- 3- Fasten the large square pieces to the wall.
- 4- Insert the product into place and tighten the fixing bolts.

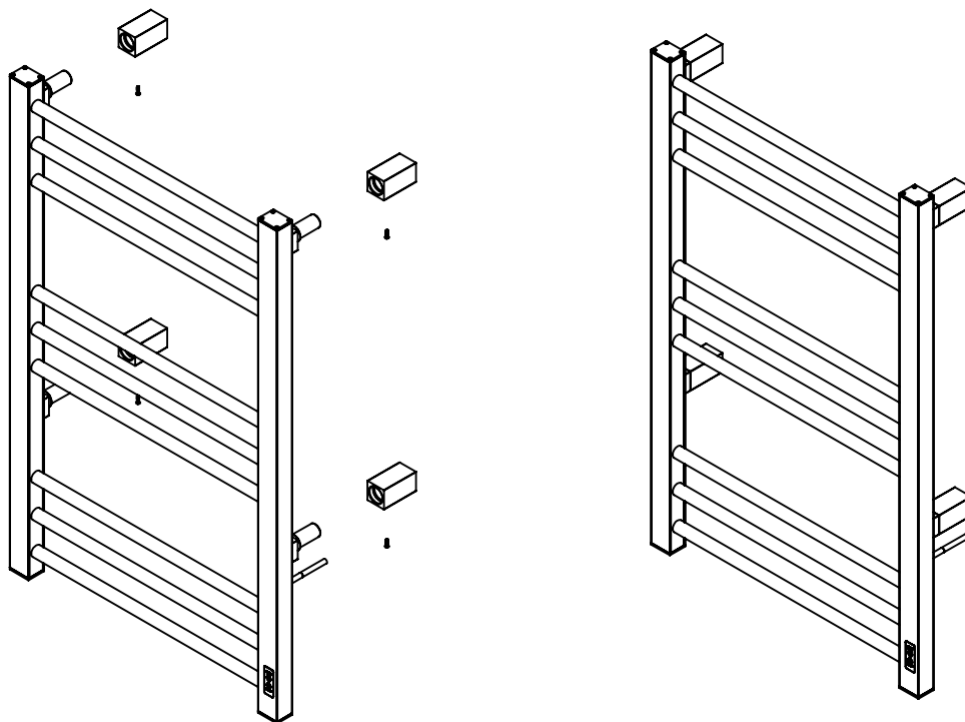

4. Operation

You can operate the product by plugging it in and touching the On/Off button.

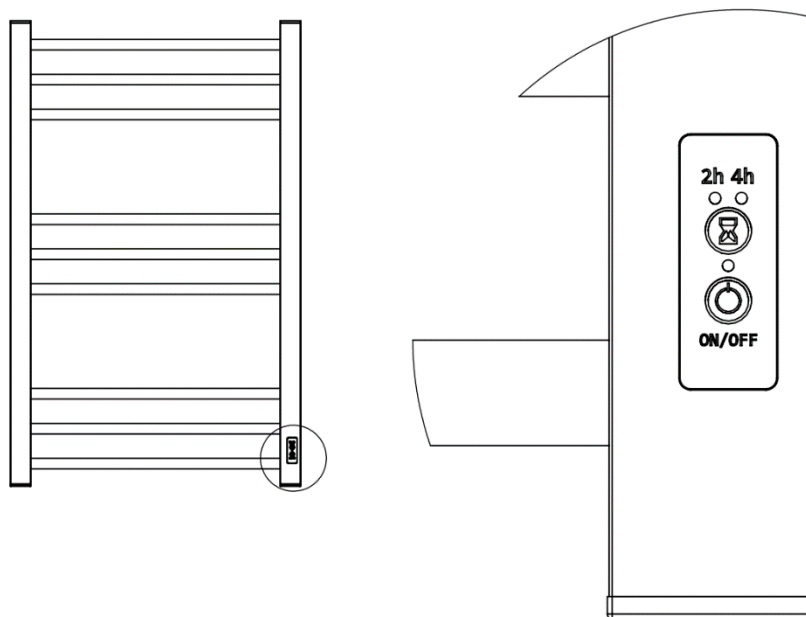

After your towel rail is plugged in, it can work in three different programs;

Program 1- The green light turns on when the On-Off key is pressed, and the towel rail works indefinitely.

Program 2- After pressing the On-Off key, the blue light turns on at the top left when the time button is pressed, the towel rail turns off automatically at the end of two hours.

5. **Program 2-** After pressing the On-Off key, the blue light turns on at the top left when the time button is pressed, the towel rail turns off automatically at the end of four hours.

6. Other

6.1 Safety features

Overheating: If the products overheats due to abnormal conditions the system will turn itself off. If overheating occurs, unplug the product and call the authorized service.

6.2 Cleaning and maintenance instructions

1. Electric Towel Rail should be cleaned regularly to remove dust on it. Regular cleaning can affect the radiator heat dissipation efficiency.
2. Unplug it and leave the towel rail to cool. Then wipe off the dust with a damp and soft cloth. Do not use detergents or abrasive products.
3. Be careful not to scratch the surface of the towel rail with hard and sharp tools. Otherwise, you can damage the paint layer.

6.3 Main technological features

Model	Ratings
EH-LILY-500-600-120	110-230V,50/60Hz,30W-120W
EH-LILY-500-600-150	110-230V,50/60Hz,35W-150W
EH-LILY-500-700-150	110-230V,50/60Hz, 35W-150W
EH- LILY-500-800-150	110-230V,50/60Hz, 35W-150W
EH- LILY-500-800-210	110-230V,50/60Hz,50W-210W
EH- LILY-500-900-240	110-230V,50/60Hz,55W-240W
EH- LILY-500-900-300	110-230V,50/60Hz,70W-300W
EH- LILY-500-1000-390	110-230V,50/60Hz,95W-390W
EH- LILY-500-1200-450	110-230V,50/60Hz,110W-450W
EH- LILY-500-1400-510	110-230V,50/60Hz,125W-510W
EH- LILY-500-1400-540	110-230V,50/60Hz,130W-540W
EH- LILY-500-1500-540	110-230V,50/60Hz,130W-540W

7. Consumer Services

Our Radial Technical Service is available 5 days a week between 08:00-18:00.

We kindly ask you to follow the suggestions below.

1. When you purchase your product, have your authorized seller confirm the warranty certificate.
2. Use your product according to the principles of the user manual.
3. When you have a service request regarding your product, please contact our Technical Service at the above phone numbers.
4. Do not forget to ask for a copy of the "technical service form" after the technical service technician provides service to you.
5. The service life of the product is 10 years. (The spare part availability period required for the product to fulfill its function)

Customer Satisfaction Policy

As Radyal Isitma Sistemleri Inc., we adopt a customer-oriented approach with the main principle of providing an excellent customer experience, where customer requests and suggestions of our brand we serve can be easily conveyed through every channel (phone, social media, letter, e-mail, dealer) regardless of customer profile; are collected in a single traceable, reportable, transparent and secure information pool, in which their records are handled in accordance with legal regulations, objectively, fairly and confidentially.

In parallel with our approach, all processes are integrated with the management system, a structure that controls each other has been developed, and management goals are also fed through this system.

Evaluation of service request

1 Customer Application

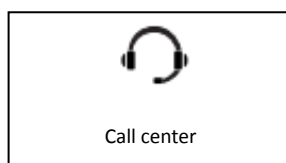

2 Application Registration

 Authorized seller

Customer Name, Surname
 Customer Phone
 Customer Address

 Call center

3 Evaluation of service request

- Service request analysis
- Informing the customer about the service (discovery, transportation, installation, information, repair, exchange, etc.)
- Performing the necessary action about the service

4 Making an appointment and performing the service

5 Receiving customer satisfaction

Satisfied

Not Satisfied

6 Closing the application record and keeping the information

Customer Considerations Regarding Warranty

This warranty provided by Radial does not cover the malfunctions caused by the use of the Electric Towel Rail outside the normal range, also the following situations are excluded from the warranty:

1. Damage and malfunctions caused by usage errors,
2. Damage and malfunctions that occur during loading, unloading and transportation after the delivery of the product to the customer,
3. Voltage drop or excess; faulty electrical wiring; damage and malfunctions caused by using the product at a voltage different than the voltage written on the label,
4. Failures and damage that may occur due to fire or lightning strikes,
5. Malfunctions caused by the use of the product contrary to the considerations contained in the user manuals.

The warranty given to the product will expire if the product is interfered with by unauthorized persons.

Repair of the above-mentioned faults is done for a fee.

Installation and transportation of the product to the place of use is not included in the product price.

The responsibility for issuing the warranty certificate to the consumer by updating it belongs to the seller, dealer, agent or representative offices where the consumer buys the product. This warranty is invalid if the warranty card has been tampered with, the original serial number on the product has been removed or has been tampered with.

Manufacturer/Importer: Radyal Isitma Sistemleri inc.

Your product has been produced by Radyal Isitma Sistemleri inc.

WARRANTY TERMS

- 1) *The warranty period starts from the delivery date of the goods and is 2 years.*

- 2) *Provided that the product is used as shown in the introduction and user manual and has not been interfered with for maintenance, repair or any other reason by persons other than the service personnel authorized by Radyal, the entirety of the goods, including all its parts; guarantees against material, workmanship and manufacturing defects for the period specified above from the date of delivery of the goods.*
- 3) *In case of understanding that the goods are defective, the consumer is obliged to comply with the requirements set out in Article 11 of the Law on Consumer Protection No. 6502*
 - a- *Customer can use one of his/her rights to, Withdrawing from the contract,*
 - b- *Request a discount from the sales price,*
 - c- *Ask for a free repair,*
 - d- *Request the replacement of the sold item with a non-defective one.*
- 4) *If the consumer chooses the right to free repair from these rights, the wrapper; is obliged to repair or have the goods repaired without any charge under any other name, such as workmanship cost, replacement part cost or any other name. The consumer can also use the right of free repair against the manufacturer. The seller and the manufacturer are jointly responsible for the consumer's exercise of this right.*
- 5) *If the consumer uses the right of free repair of the goods;*
 - *In cases where it fails again within the warranty period,*
 - *The maximum time required for repair is exceeded,*
 - *And it is determined by a report by the authorized service station, the seller or the manufacturer that the repair is not possible;*

The consumer may request from the seller a refund of the price of the goods, a reduction in the amount of the defect or, if possible, replacement of the goods with a non-defective one. The seller cannot refuse the consumer's request. In case of non-fulfillment of this request, the seller, the manufacturer and the importer are jointly and severally liable.
- 6) *The repair time of the goods cannot exceed 30 working days. This period begins on the date of notification of the malfunction of the product to the authorized service station or seller during the warranty period and from the date of delivery of the product to the authorized service station outside the warranty period. If the failure of the goods cannot be fixed within 15 working days, the manufacturer must allocate another product with similar characteristics for the use of the consumer until the repair of the goods is completed. In case of malfunction of the product within the warranty period, the period of repair is added to the warranty period.*
- 7) *Malfunctions caused by the use of the product contrary to the considerations contained in the user manual are outside the scope of the warranty.*
- 8) *The Consumer may apply to the Consumer Arbitration Committee or Consumer Court at the place where the settlement is located or where the consumer transaction is made in case of disputes that may arise regarding the exercise of his/her rights arising from the warranty.*
- 9) *In the event that this Warranty Document is not issued by the Seller, the consumer may contact the General Directorate of Consumer Protection and Market Supervision of the Ministry of Customs and Trade.*

WARRANTY CERTIFICATE

BRAND : RADYAL
TYPE : ALUMINUM ELECTRIC RADIATOR/TOWEL RAIL
MODEL :
SERIAL NO :
DELIVERY DATE :
WARRANTY PERIOD : 2 YEARS

MANUFACTURER COMPANY'S

TITLE : RADYAL ISITMA SİSTEMLERİ A.Ş.
ADDRESS : Pelitli Mh. Şantiye Cd. No:20/B İç Kapı No:3 Gebze/KOCAELİ
PHONE : +90 850 308 08 08
E-MAIL : info@radyal.com



RADYAL ISITMA SİSTEMLERİ A.Ş.
Libadiye Cumhuriyet Mah.
Şair Mehmet Akif Ersoy Cad.
No: 42 Üsküdar - İSTANBUL
Anadolu Kurumlar V.D.: 734 073 6661



TECHNICAL SERVICE

TITLE : RADYAL ISITMA SİSTEMLERİ A.Ş.
ADDRESS : Pelitli Mh. Şantiye Cd. No:20/B İç Kapı No:3 Gebze/KOCAELİ
PHONE : +90 850 308 08 08

SELLER COMPANY'S

TITLE :
ADDRESS :
PHONE :
E-MAIL :

DATE, SEAL AND SIGNATURE